

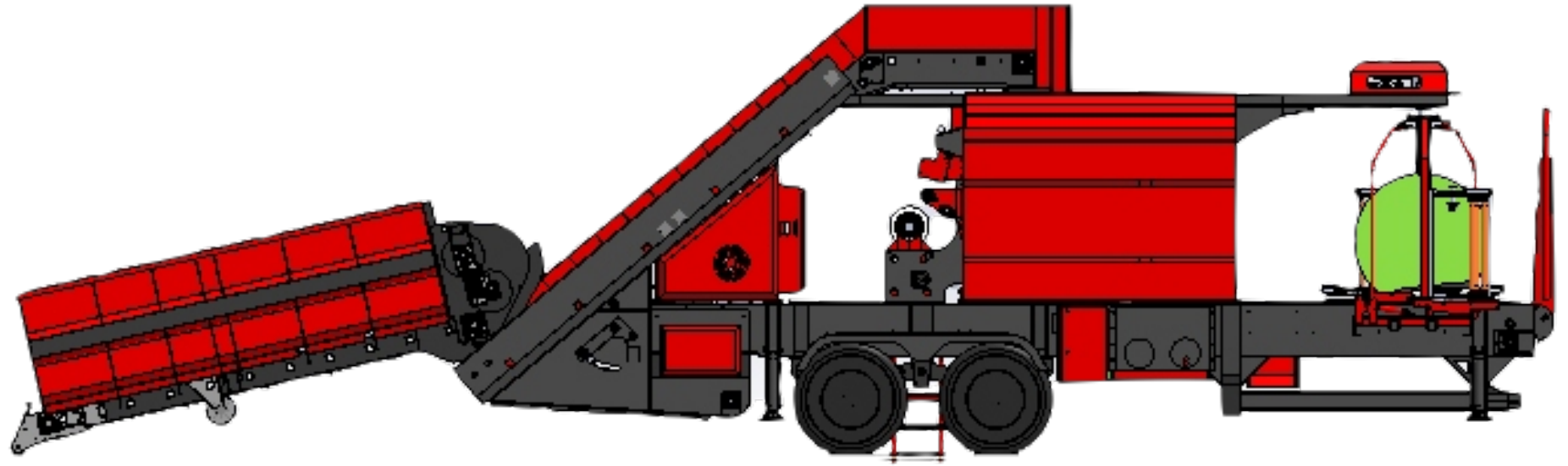

YERLİ MAKİNA



COMPRESS - 120

TEKNİK KATALOG



YERLİ MAKİNA

BALYA ÜRETİM ŞEMASI

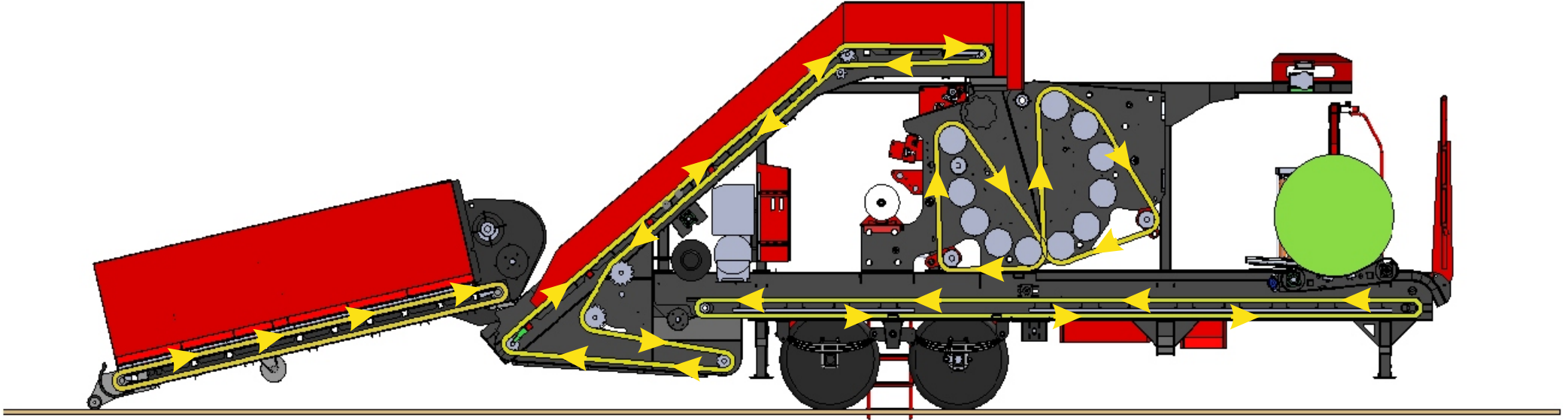

TEKNİK KATALOG

TARİH : 26.02.2022
MODEL : COMPRESS 120 VARIO



YERLİ MAKİNA

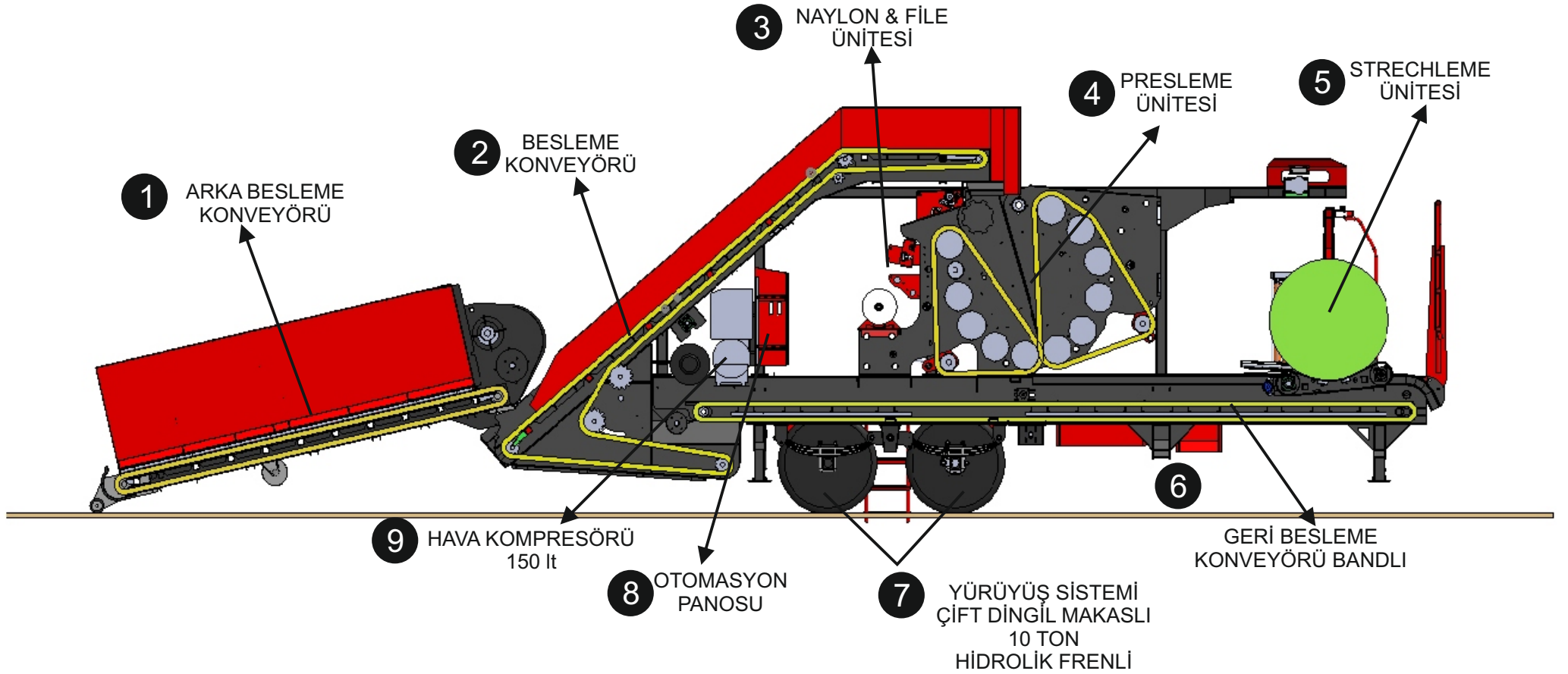

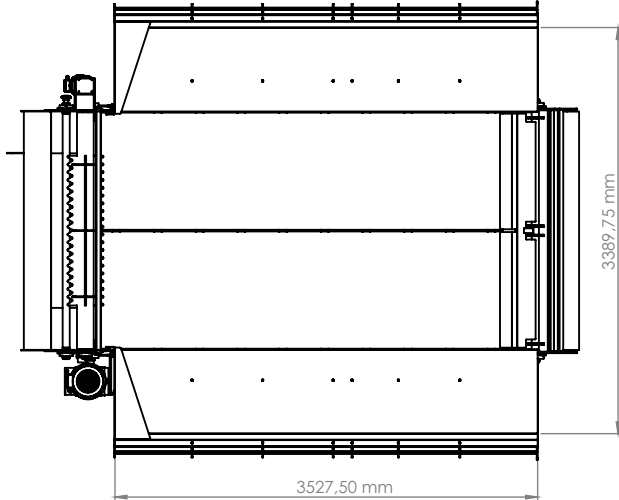
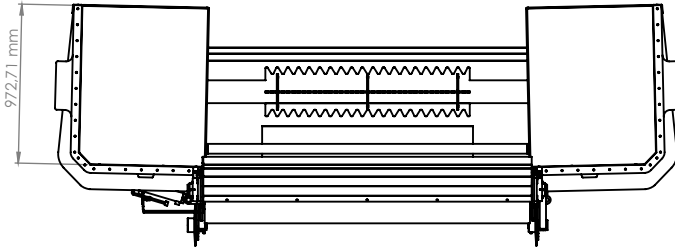

DAĞITICI
HELEZON

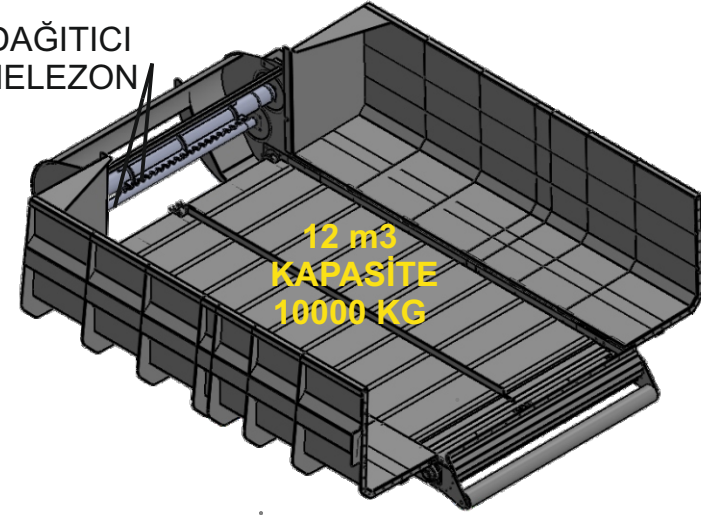

Kapsite 12m3 10 tondur.

4 adet zincir kullanılarak tahrik edilmektedir.

Paletler vidalı olarak montajlanmıştır.

Düşük eğime sahip olduğu için geri kaçırma yapmaz.

Motor ve redüktör yılmaz marka KR serisi kullanılmıştır.

Hız kontrol cihazı hızı istenilen seviyede ayarlanabilir.

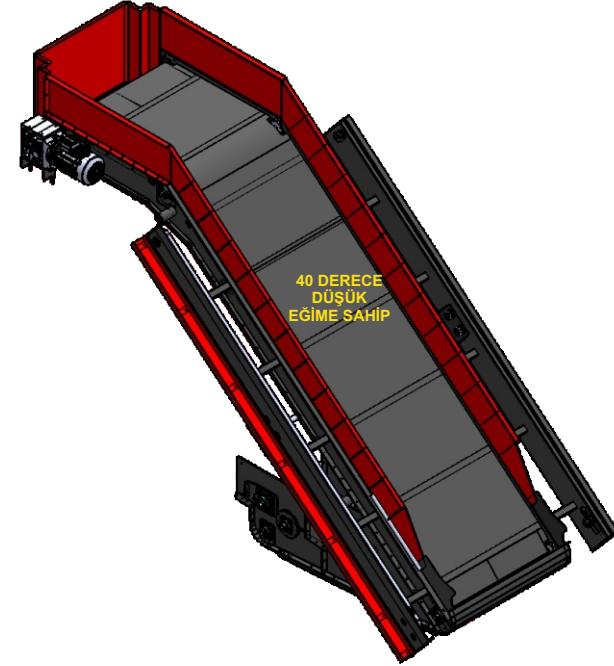
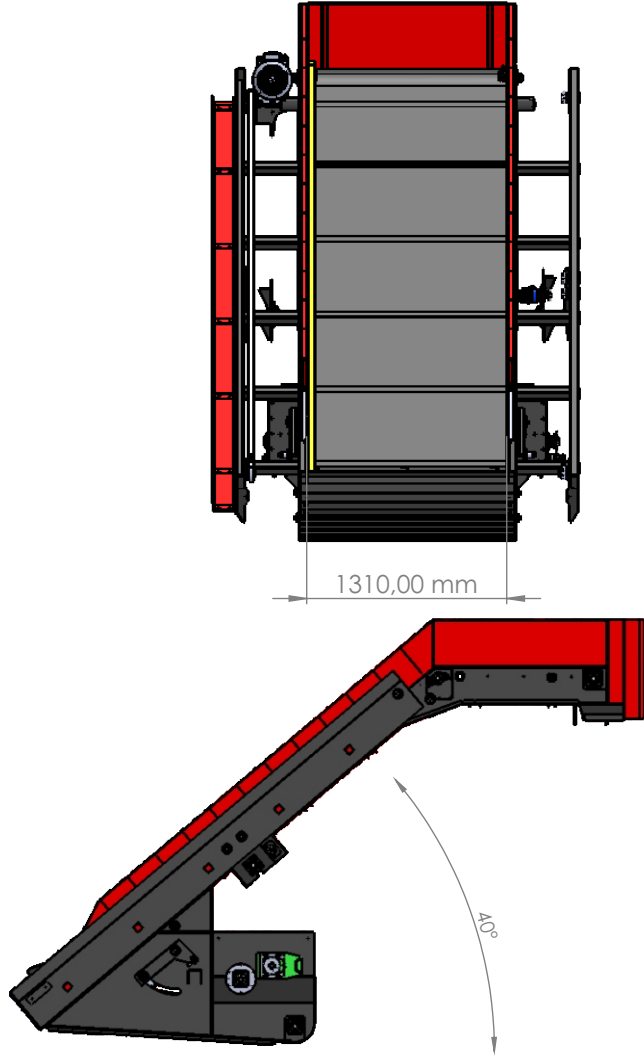

2 adet zincir kullanılarak tahrik edilmektedir.
Paletler vidalı olarak montajlanmıştır.
Düşük eğime sahip olduğu için geri kaçırma yapmaz.
Motor ve redüktör yılmaz marka KR serisi kullanılmıştır.
Hız kontrol cihazı hızı istenilen seviyede ayarlanabilir.

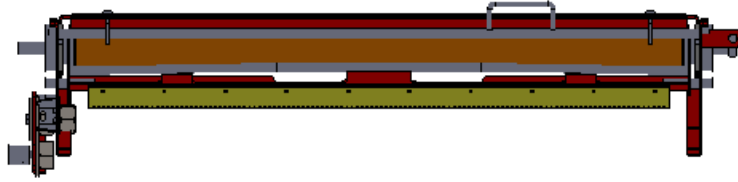

NAYLON FİLE KESME ÜNİTESİ

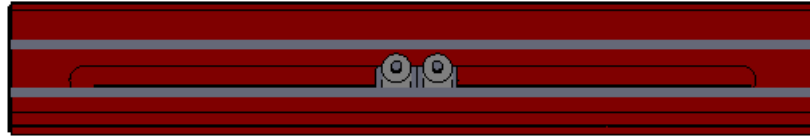

NAYLON FİLE TOPLAMA YAYMA ÜNİTESİ



ELEKTRONİK GERGİ KONTROL SİSTEMİ
file veya naylon için ekrandan ayarlanabilen
elektronik tansiyon kontrol sistemi

FİLE NAYLON SÖKME TAKMA İÇİN KOLAY KLEMP SİSTEMİ .

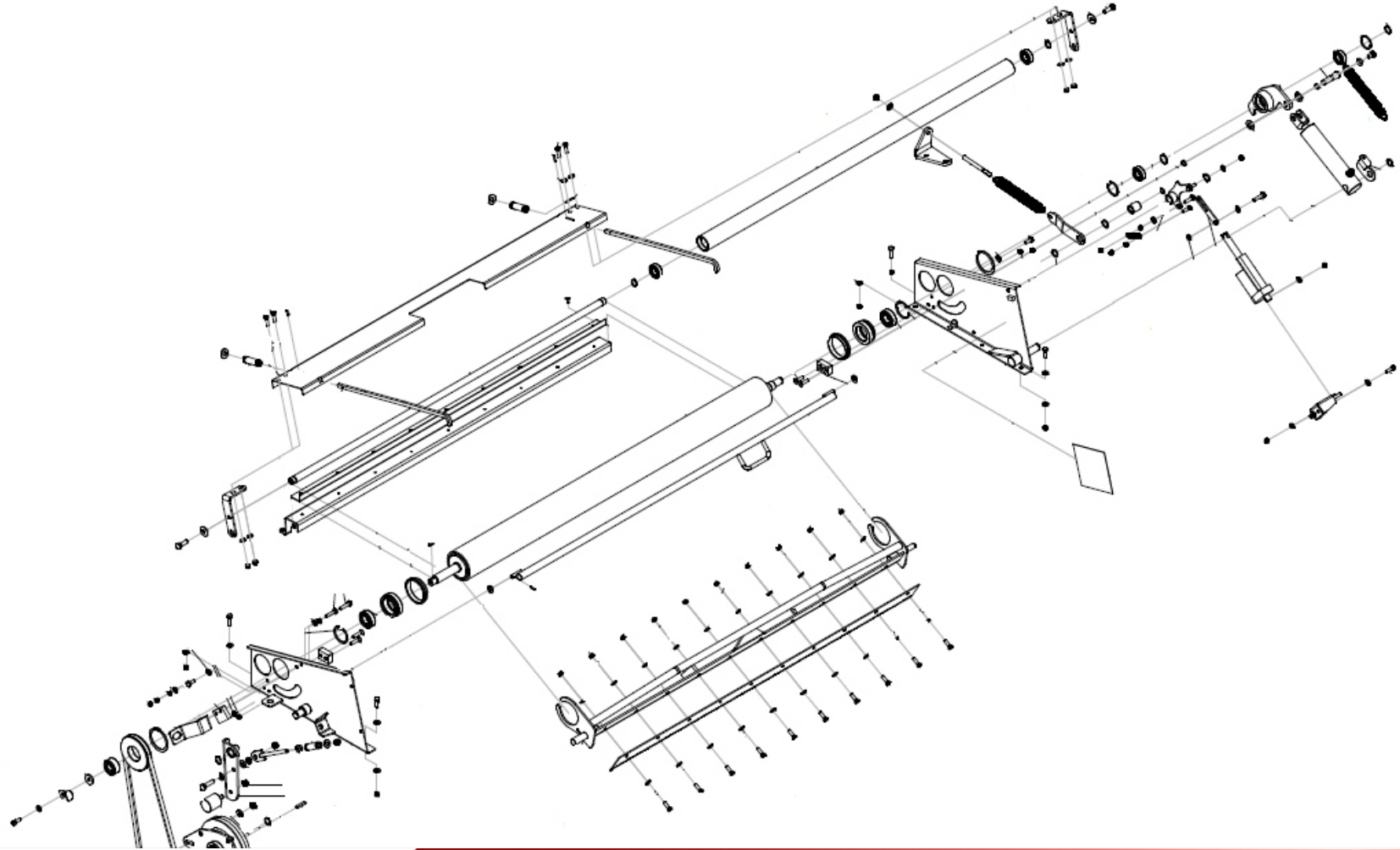

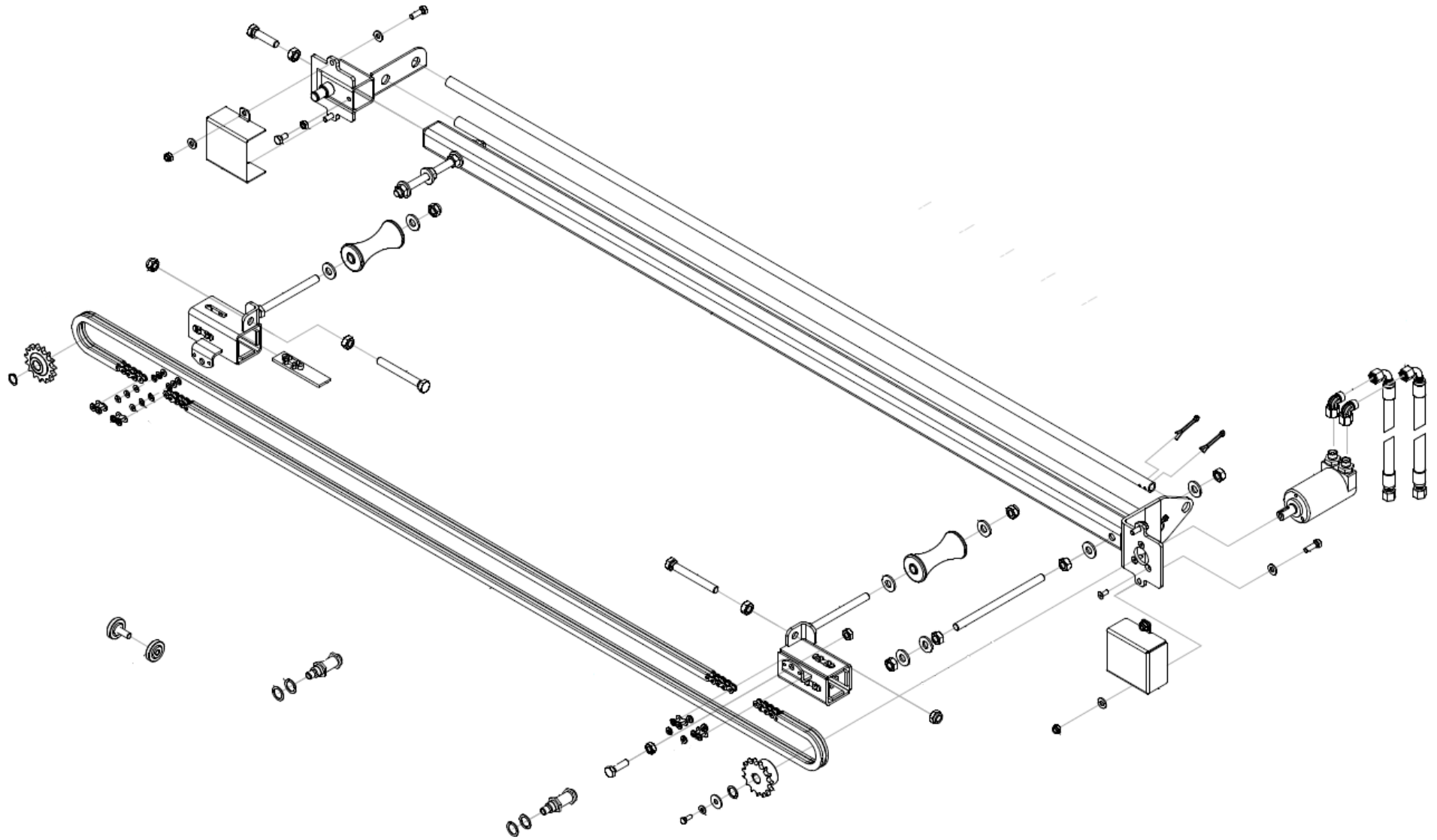



YERLİ MAKİNA

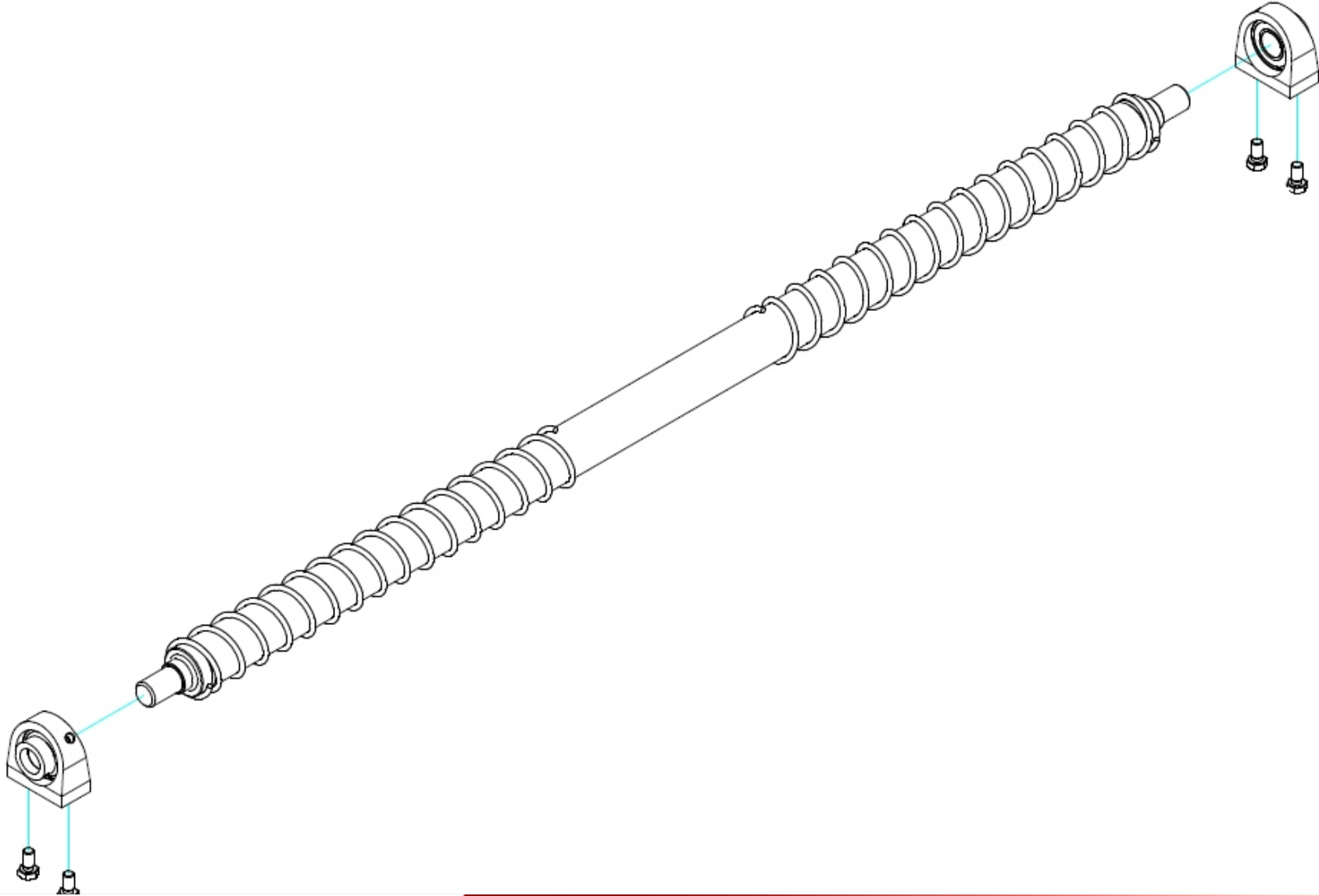

TEKNİK KATALOG

TARİH : 26.02.2022
MODEL : COMPRESS 120 VARIO



Kapsite 500 kg ila 1200 kg arasında ayarlanabilir.
Zencirler 24b1 aktarmalı tahrikli
Tambur içlerinden boydan boya mil geçer

İç yapıdaki band ve tamburların konumlandırılması sayesinde pres odası içine 100 kg ürün girdikten sonra ürün dönmeye ve sıkışmaya başlar bu sayede balya içinden beri sıkı sarılır. Diğer sistemelerde bu yapı çok düzgün olmadığı için oda içerisine 500kg ürün girinceye kadar ürün oda içerisinde dönmez ve sıkışmaz çokça tıkama ve taşıma problemi ile karşılaşılır aynı zamanda balyanın orta kısmı gevşek kalır odadan çıkan balya çabuk dağılır.

Band gergi sistemlerimiz hidroliktir ön ve arka band güçleri olarak ayrı ayrı ayarlanabilir. Yay gergili sistemlerden farkımız yay gerildiğinde balya küçükken farkı güçte balya büyüdükçe farklı güçte sıkılık yapar o yüzden balyanın orta kısmı çok gevşek kalır ve balya pres odasından çıktıktan sonra çabuk yıkılır.

Motor ve redüktör yılmaz marka KR serisi kullanılmıştır.
Hız kontrol cihazı hızı istenilen seviyede ayarlanabilir.

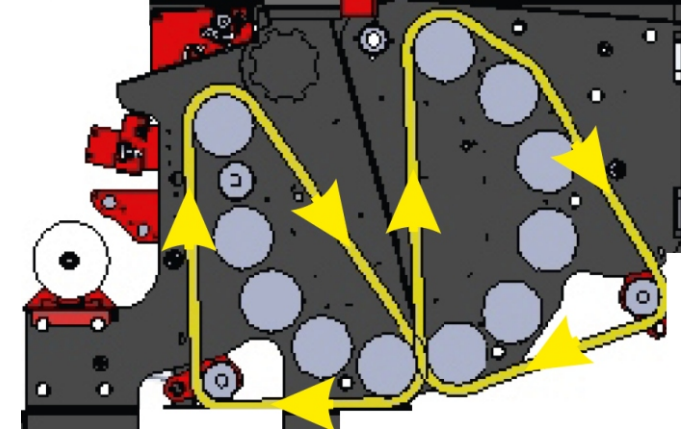



PRES ODASI ZENCİRLERİ (24B1)

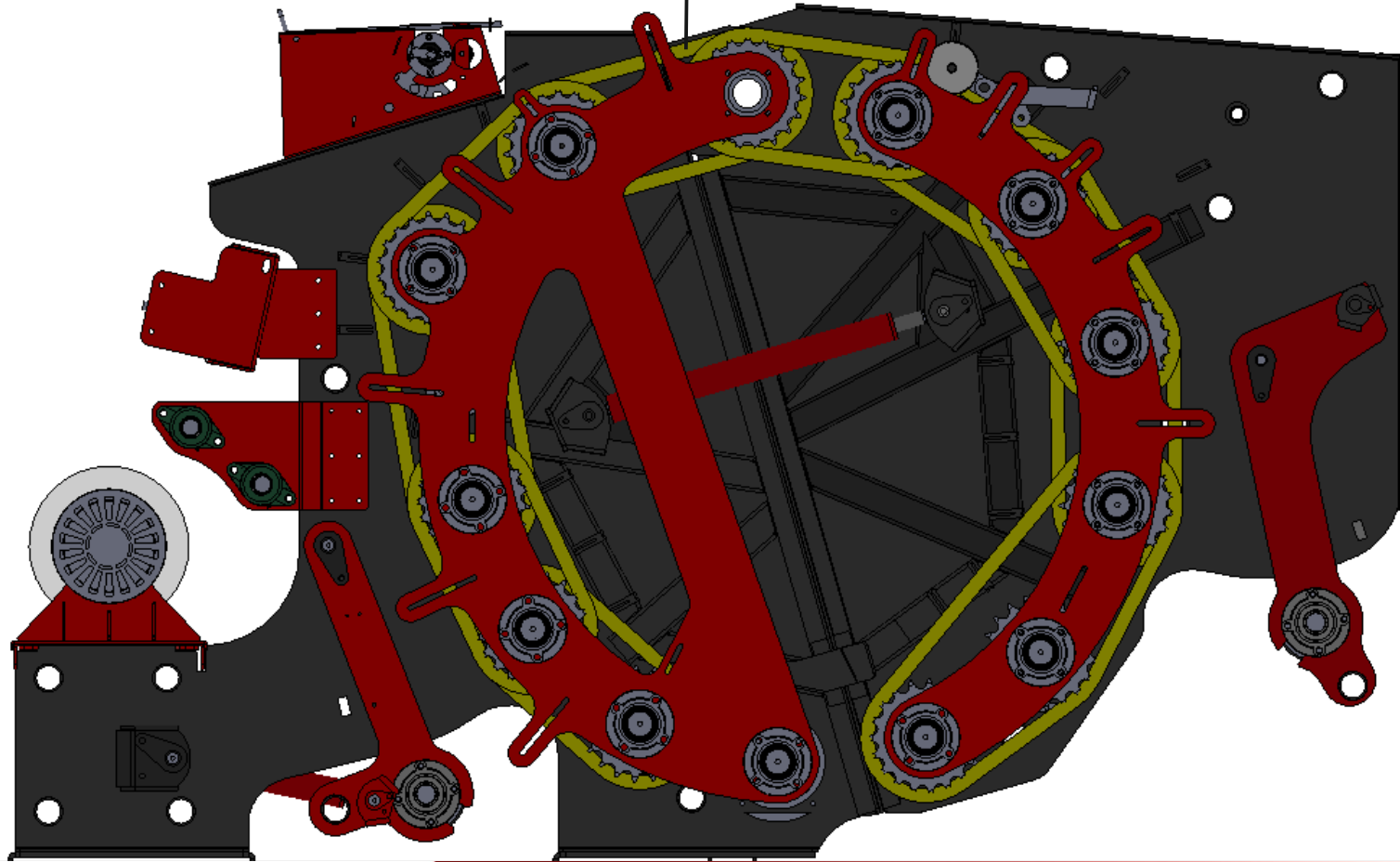



PRESSING ROOM COVER CYLINDER

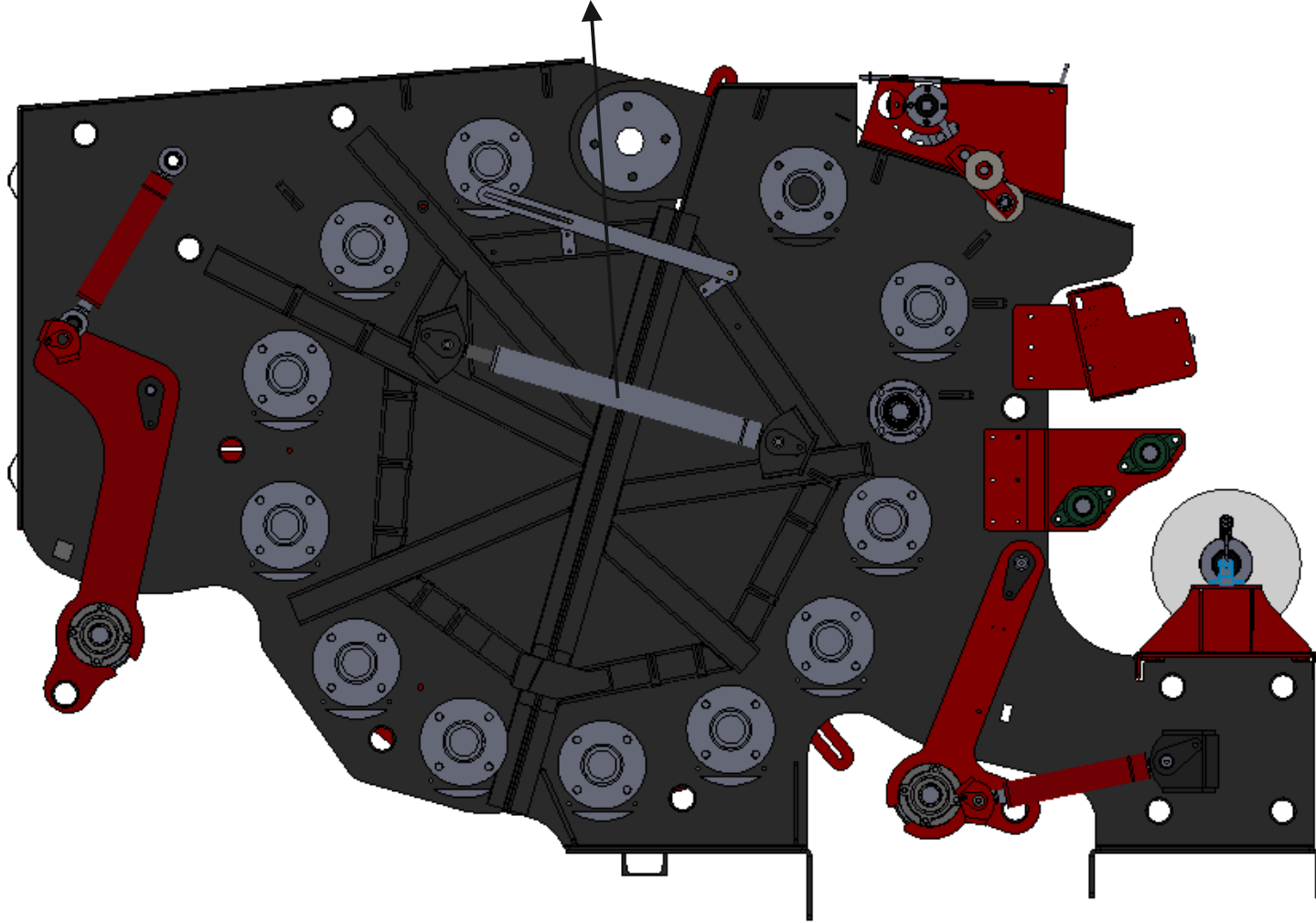

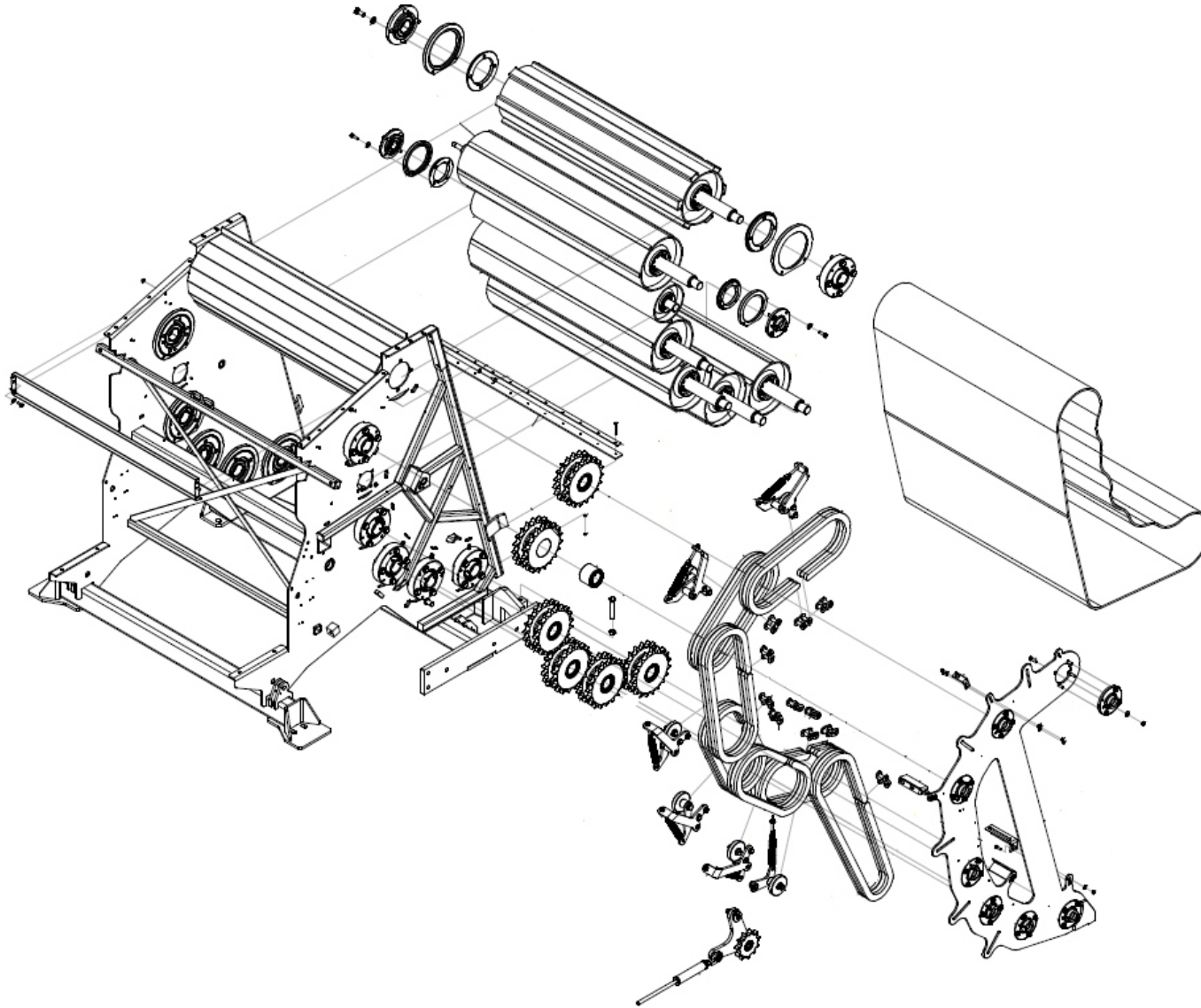

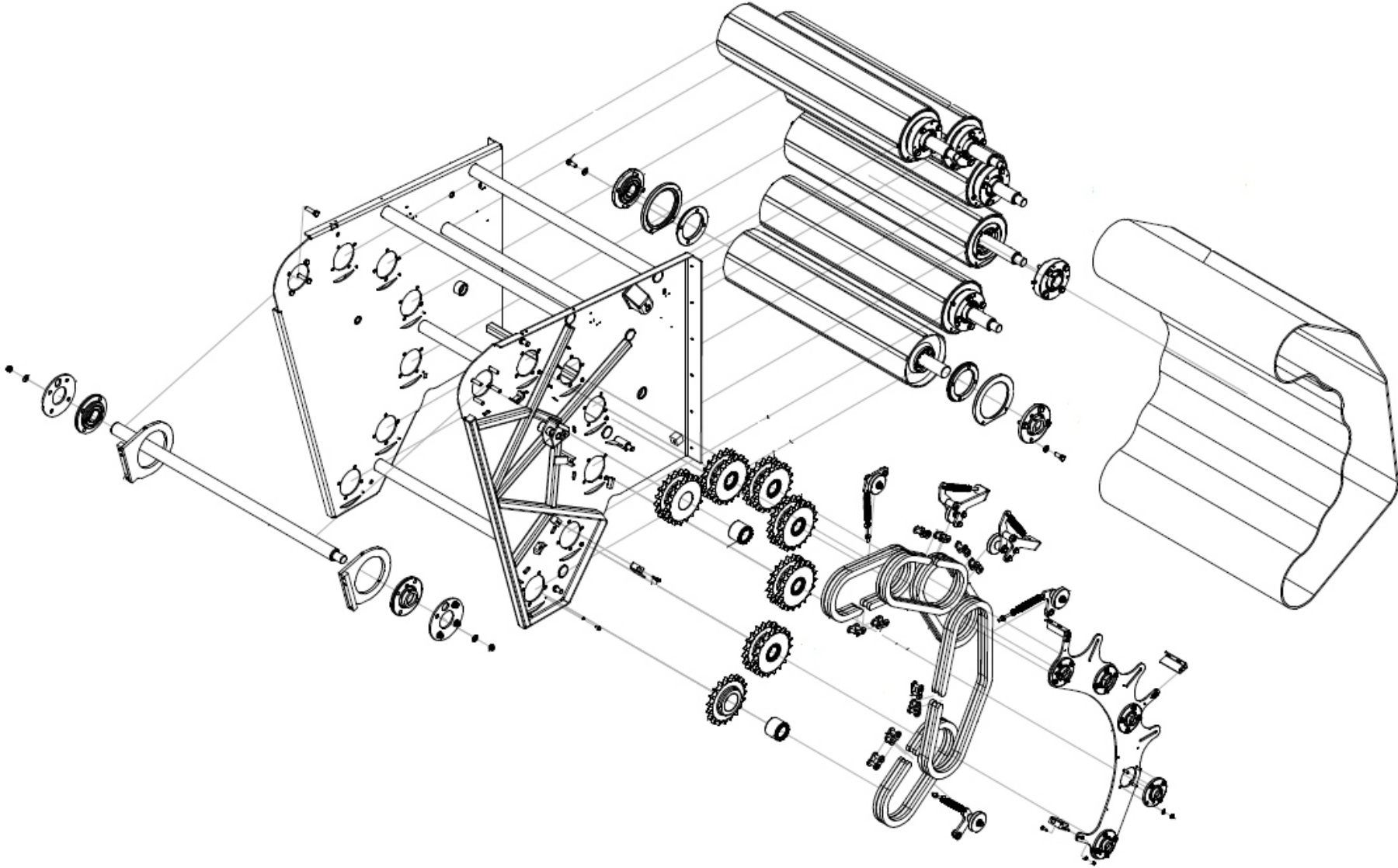



YERLİ MAKİNA

4

PRES ODASI HİDROLİK BAND GERGİ

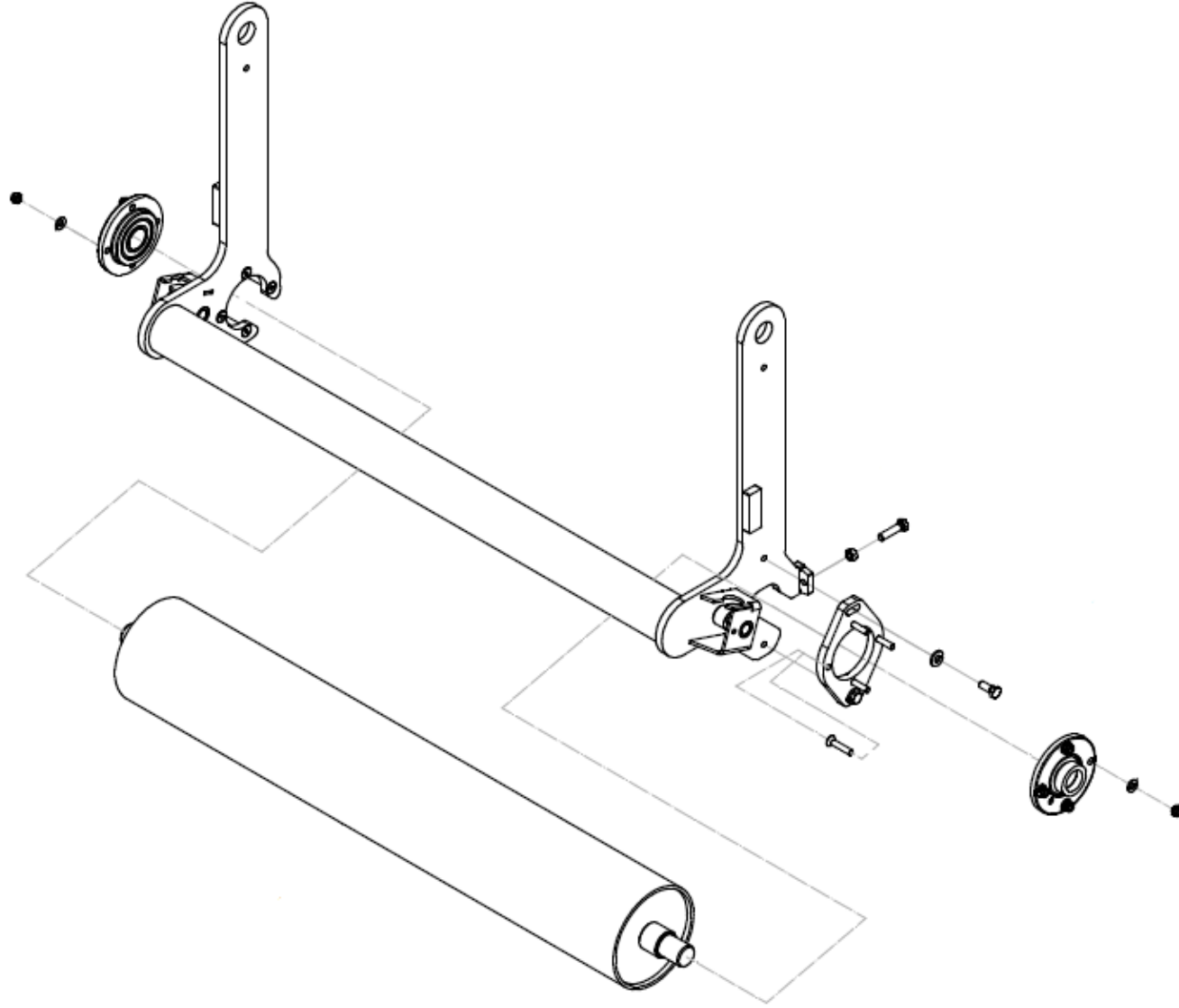

TEKNİK KATALOG

TARİH : 26.02.2022

MODEL : COMPRESS 120 VARIO



YERLİ MAKİNA

9 HAVA KOMPRESÖRÜ



TEKNİK KATALOG

TARİH : 26.02.2022
MODEL : COMPRESS 120 VARIO



YERLİ MAKİNA

4

PRES ODASI HİDROLİK BAND GERGİ

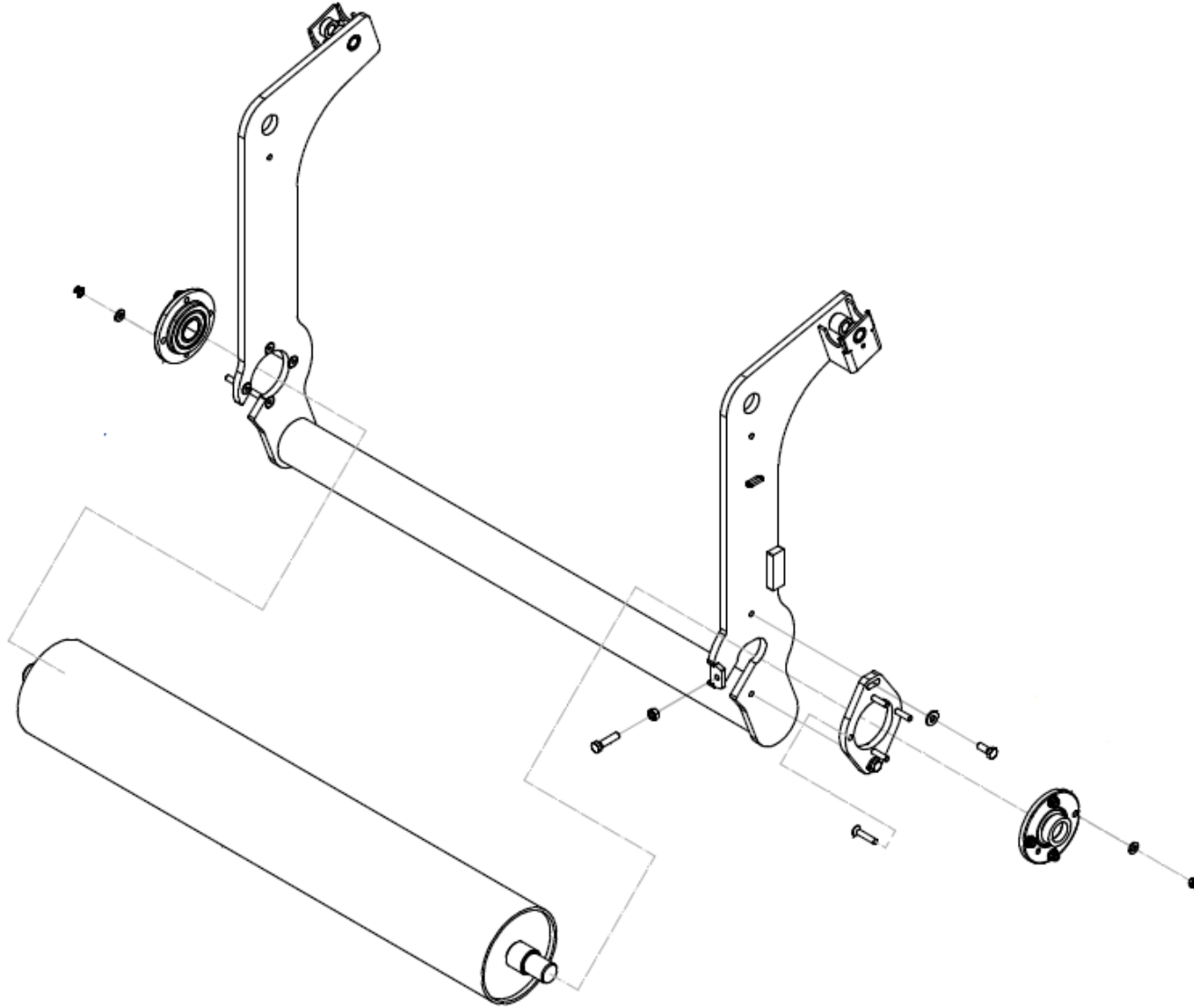

TEKNİK KATALOG

TARİH : 26.02.2022

MODEL : COMPRESS 120 VARIO



GÜVENLİK KOLLARI

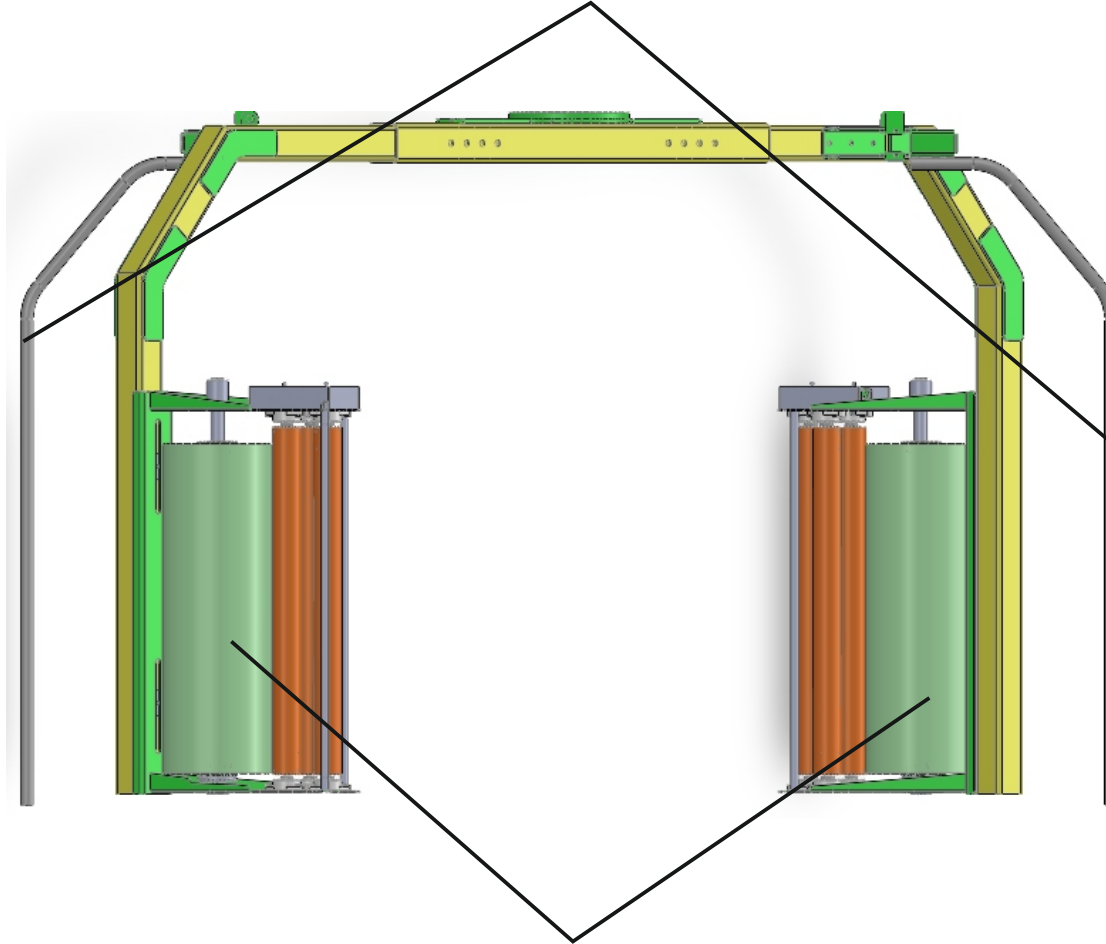

STRETCH WRAPPING UNIT

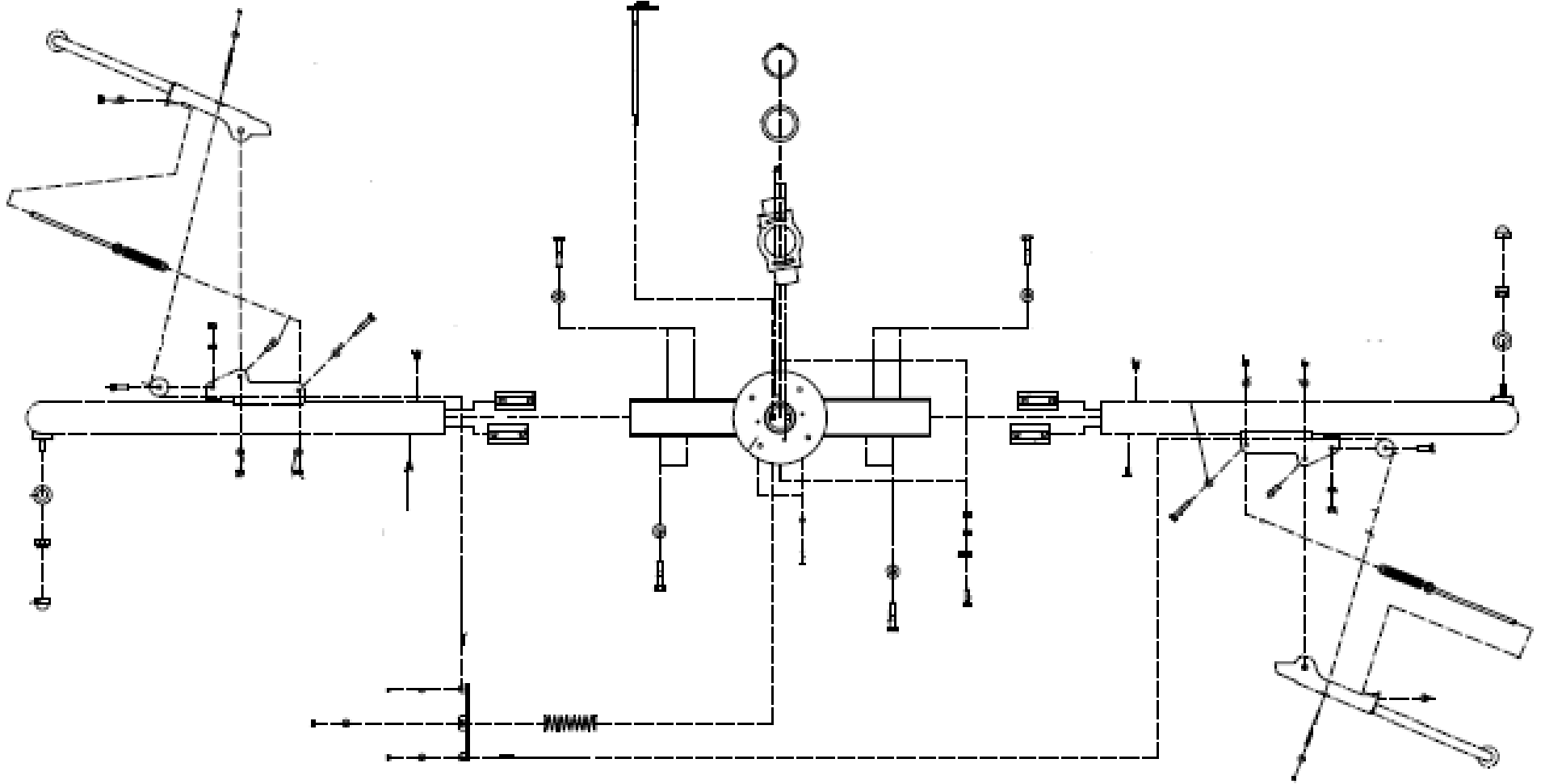

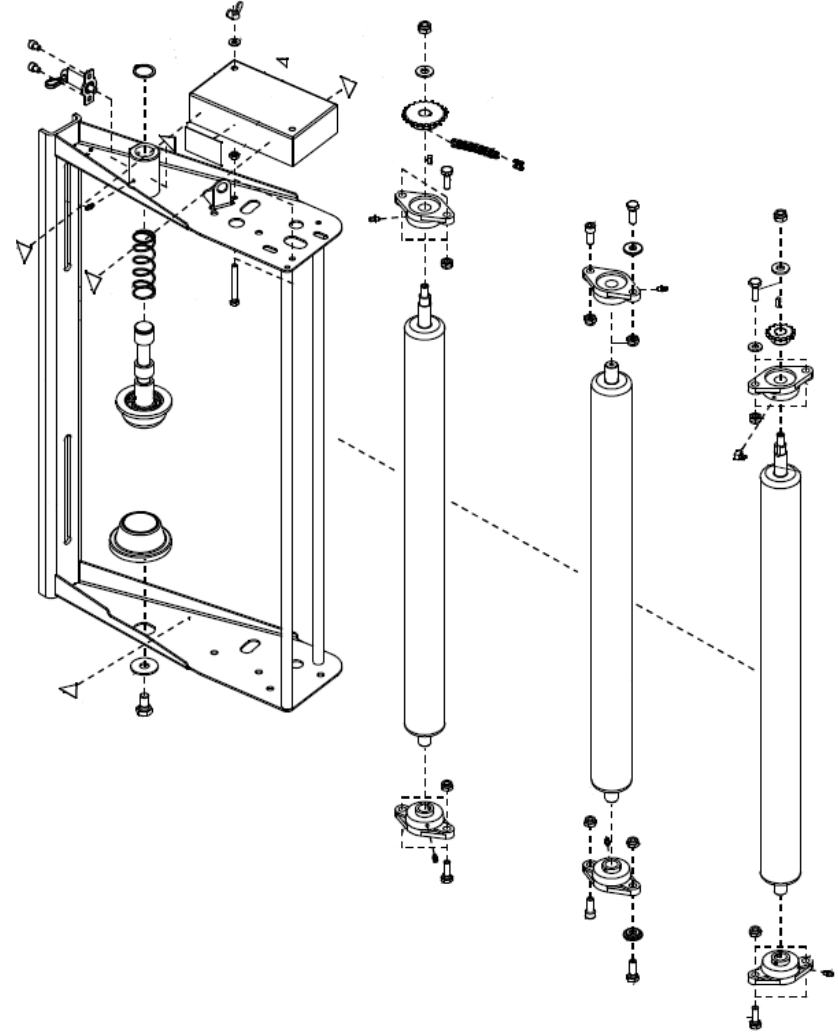
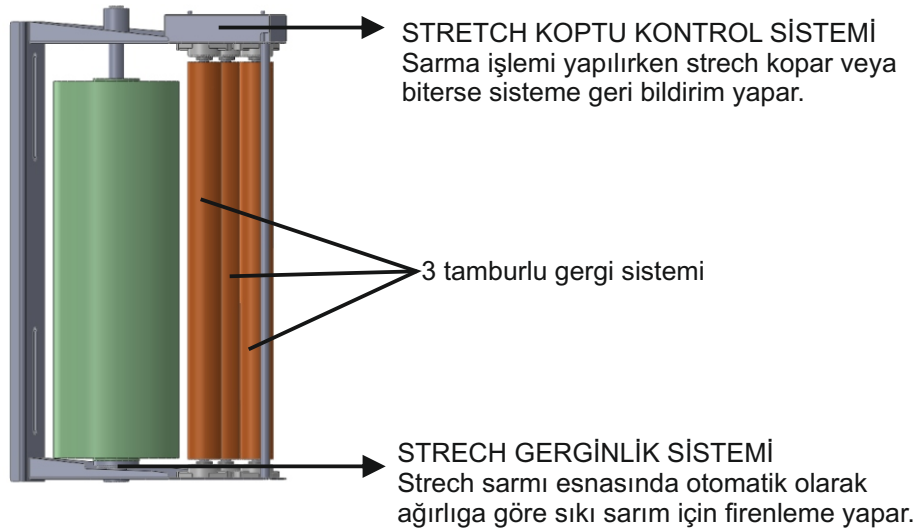

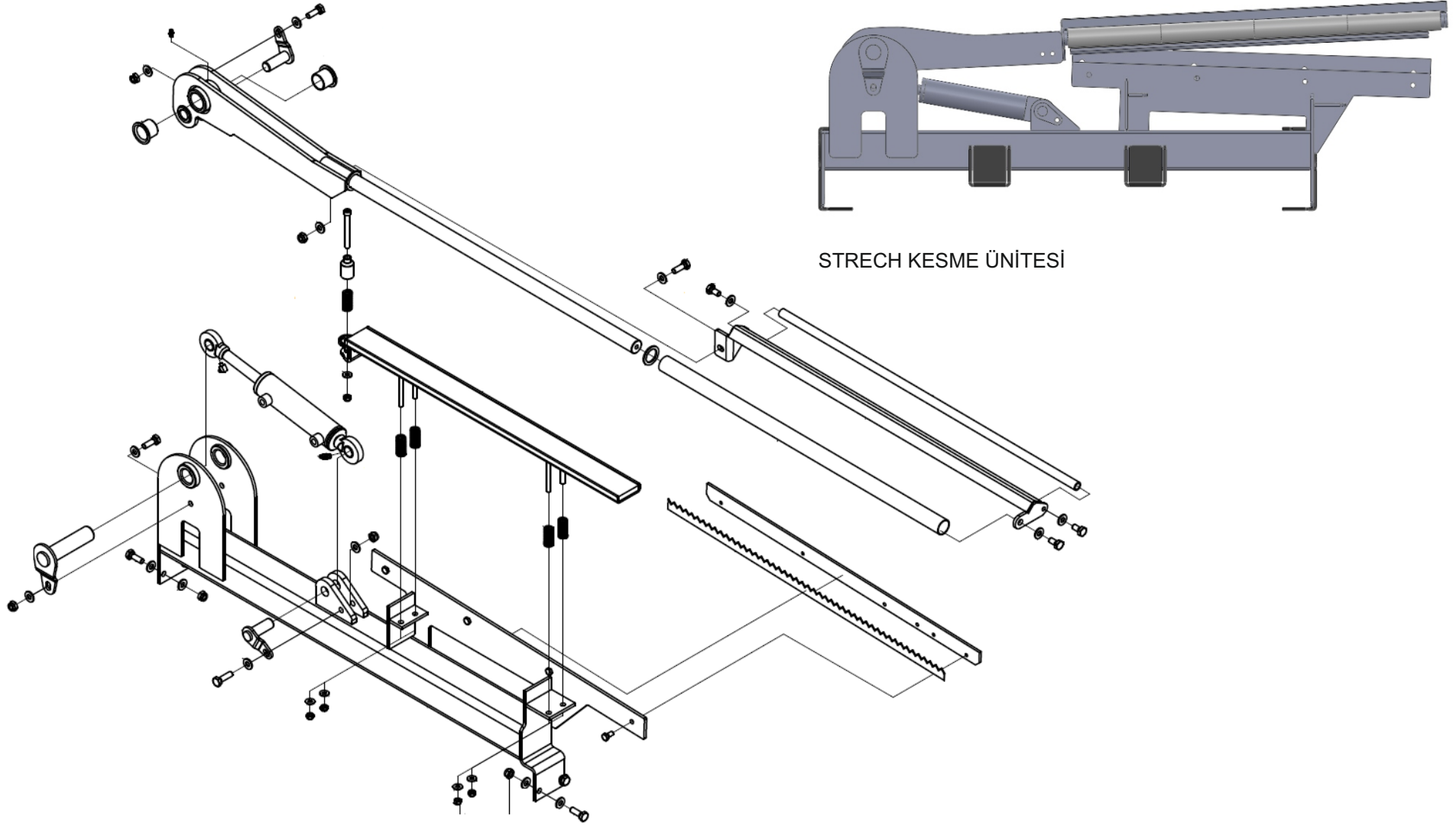

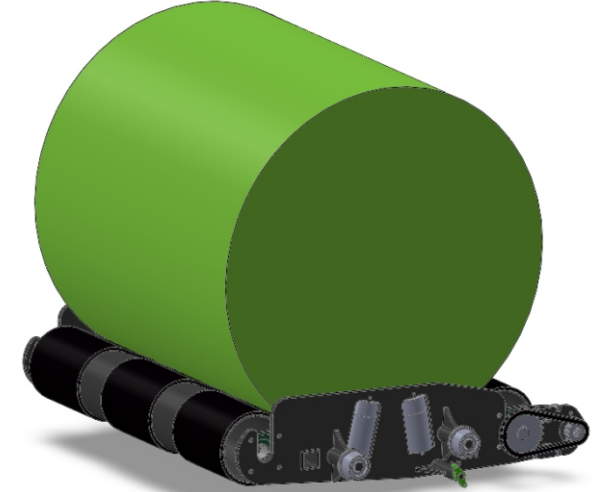
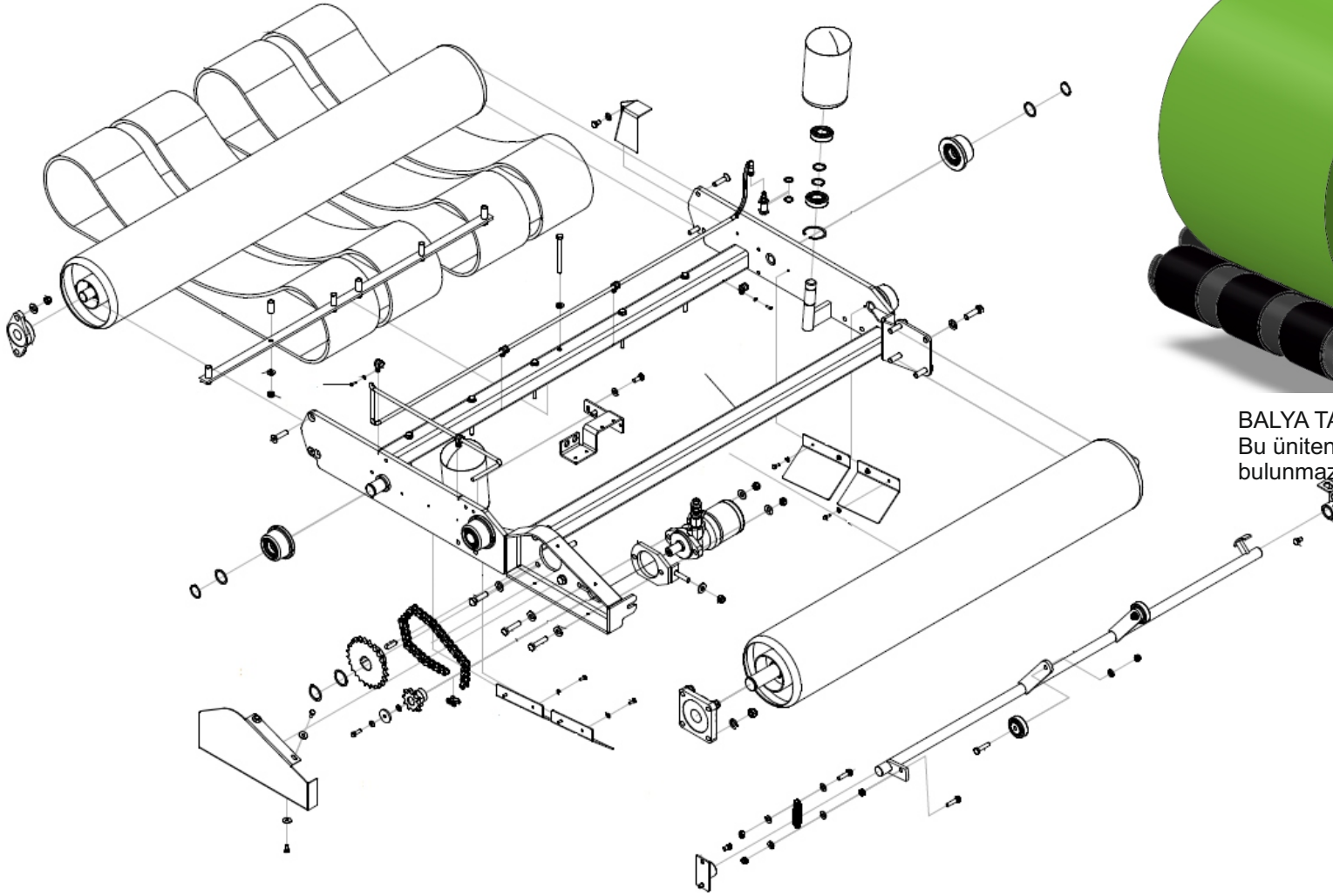

BALYA TAŞIYICI ÜNİTE

Bu ünitenin hareket yolu üzerinde herhangi bir sensör bulunmaz bu sayede sorunsuz çalışır.

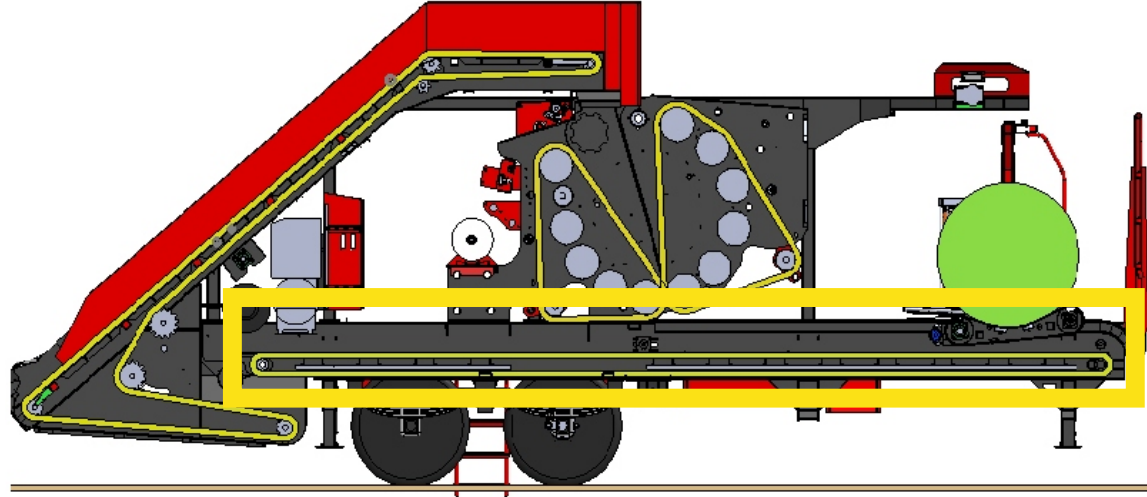

Çalışma esnasında dökülen ürünleri besleme konveyörüne taşıyarak ürünler makina etrafına veya altına dökülmesi engelleyerek tekrar balyalama ünitesine geri götürür 4 mm pvc band kullanılmıştır. Çalışma hızı ve şekli ayarlanabilir.

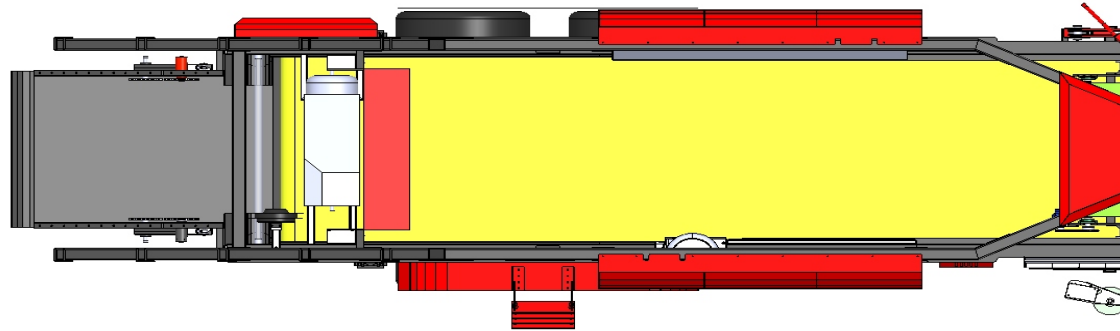

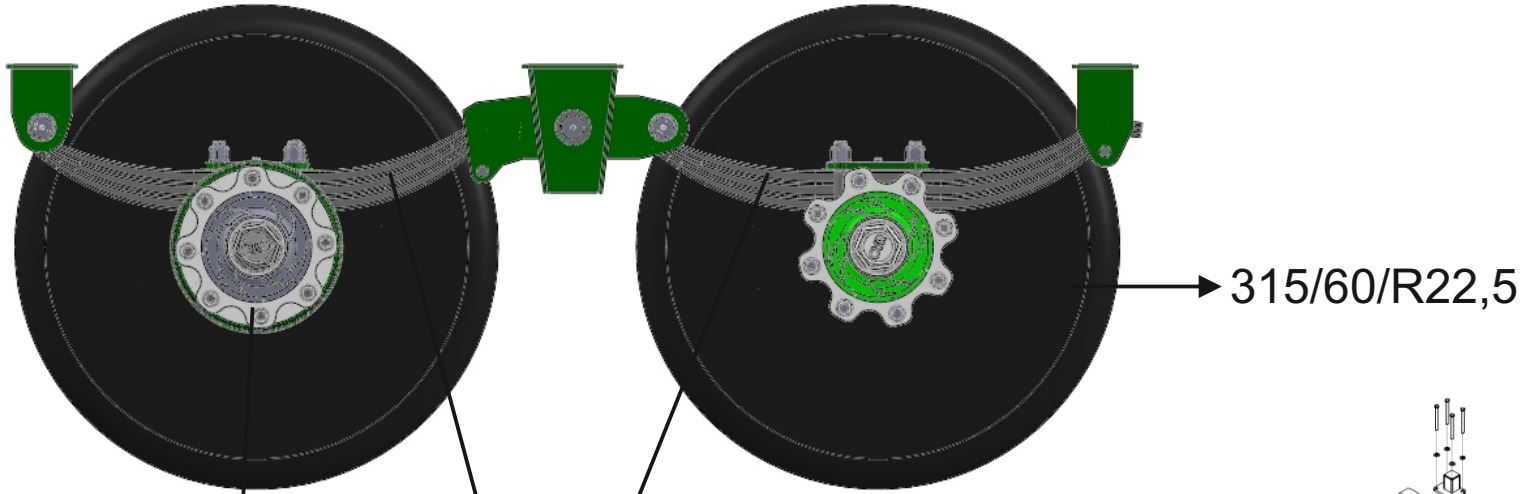

HİDROLİK FREN SİSTEMİ

MAKAS SİSTEMİ 18 TON

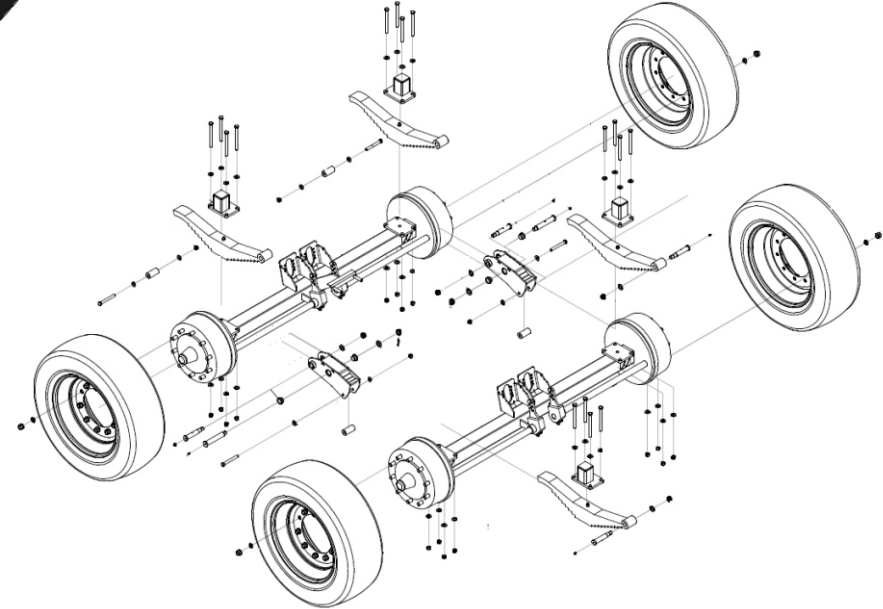



PLC CPU - I/O CONTROL BOARD

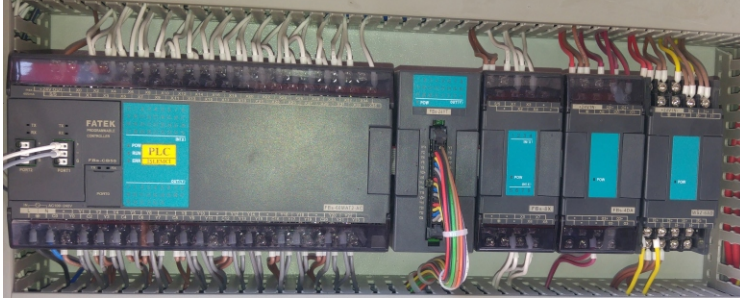

MOTOR HIZ KONTROL CİHAZLARI



HYDRAULIC VALVE CONTROL BOARDS

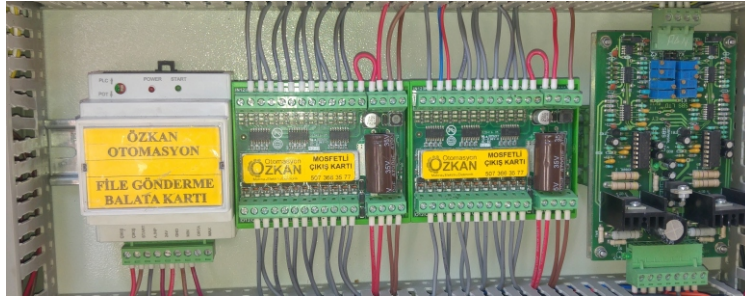

PROTECTION SWITCHES



PLUG CONNECTION SYSTEM FOR EASY ASSEMBLY AND DISASSEMBLY.

